

December 7, 2025



"Repent,
for the
kingdom of heaven
has come near."

Matthew 3:2



MT. ZION

Evangelical Lutheran Church
Madison Heights, MI

Pastor Tom Naumann
(248) 677-7242

mtzionlutheran.info



2nd Sunday in Advent

Pre-Service Personal Prayer: *Lord God, heavenly Father, send Your Son into our hearts by the power of Your Holy Spirit, that we, being strengthened by the Sun of Righteousness, may walk before You in fervent faith and all holy obedience. Watch over our little flock, and by Your Word strengthen our faith and renew in us a rejoicing spirit in our Advent and Christmas worship. Amen.*

Today's Order of Service

Greeting and Prayer

Opening Hymn 331 *The Advent of Our King*

1 *The advent of our King Our prayers must now employ,
And we must hymns of welcome sing In strains of holy joy.*

2 *The everlasting Son Incarnate deigns to be,
Himself a servant's form puts on To set His servants free.*

3 *O Zion's daughter, rise To meet your lowly King,
Nor let your faithless heart despise The peace He comes to bring.*

4 *As judge, on clouds of light, He soon will come again
And His true members all unite With Him in heav'n to reign.*

5 *Before the dawning day Let sin's dark deeds be gone,
The sinful self be put away, The new self now put on.*

6 *All glory to the Son, Who comes to set us free,
With Father, Spirit, ever one Through all eternity.*

The Invocation

We invoke ("call upon") the name of the one true God – Father, Son, and Holy Spirit.

P In the name of the Father, and of the Son, and of the Holy Spirit.

C Amen!

The Confession and Absolution of Sins

We come before our Holy God admitting that we are sinful and need His forgiveness.

P We have come into the presence of God, who created us to love and serve Him as His dear children. But we have disobeyed Him and deserve only His wrath and punishment. Therefore, let us confess our sins to Him and plead for His mercy.

C Merciful Father in heaven, I am altogether sinful from birth. In countless ways I have sinned against You and do not deserve to be called Your child. But trusting in Jesus, my Savior, I pray: Have mercy on me according to Your unfailing love. Cleanse me from my sin, and take away my guilt.

P God, our heavenly Father, has forgiven all your sins. By the perfect life and innocent death of our Lord Jesus Christ, He has removed your guilt forever. You are His own dear child. May God give you strength to live according to His will!

C Amen!

Lord, Have Mercy

Kyrie – Latin for “O Lord.” We approach our Lord with a cry for help in all the needs of our earthly life.

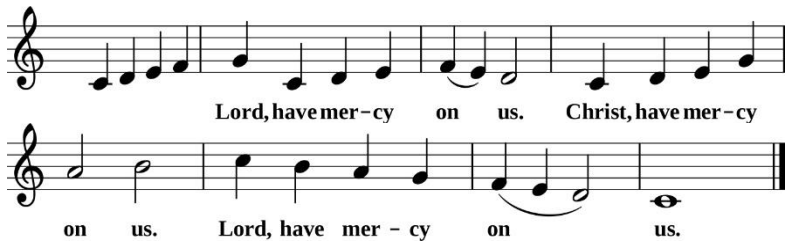

The “O” Antiphons *(Hymn 357:3-4 O Come, O Come, Emmanuel)*

Advent means “coming.” During the Advent season, we pray for the Messiah Jesus to come and make His home with us.

These hymn verses are a part of the “O” Antiphons—ancient chants which formed the basis for “O Come, O Come, Emmanuel.

C  *O come, O come, Thou Lord of might,
Who to Thy tribes on Sinai's height
In ancient times didst give the Law
In cloud and majesty and awe.
Rejoice! Rejoice! Emmanuel
Shall come to thee, O Israel!*

*O come, Thou Branch of Jesse's tree,
Free them from Satan's tyranny
That trust Thy mighty pow'r to save,
And give them vict'ry o'er the grave.
Rejoice! Rejoice! Emmanuel
Shall come to thee, O Israel!*



The Prayer for the Day

The main thoughts for the day are collected together in this prayer.

P Let us pray. . . through Christ Jesus, Your Son, our Lord, who lives and reigns with you and the Holy Spirit, one God, now and forever.

C Amen.

The Old Testament Reading: *Isaiah 11:1-10*

There shall come forth a shoot from the stump of Jesse, and a branch from his roots shall bear fruit. ² And the Spirit of the LORD shall rest upon him, the Spirit of wisdom and understanding, the Spirit of counsel and might, the Spirit of knowledge and the fear of the LORD. ³ And his delight shall be in the fear of the LORD. He shall not judge by what his eyes see, or decide disputes by what his ears hear, ⁴ but with righteousness he shall judge the poor, and decide with equity for the meek of the earth; and he shall strike the earth with the rod of his mouth, and with the breath of his lips he shall kill the wicked. ⁵ Righteousness shall be the belt of his waist, and faithfulness the belt of his loins. ⁶ The wolf shall dwell with the lamb, and the leopard shall lie down with the young goat, and the calf and the lion and the fattened calf together; and a little child shall lead them. ⁷ The cow and the bear shall graze; their young shall lie down together; and the lion shall eat straw like the ox. ⁸ The nursing child shall play over the hole of the cobra, and the weaned child shall put his hand on the adder's den. ⁹ They shall not hurt or destroy in all my holy mountain; for the earth shall be full of the knowledge of the LORD as the waters cover the sea. ¹⁰ In that day the root of Jesse, who shall stand as a signal for the peoples of him shall the nations inquire, and his resting place shall be glorious.

The Responsive Reading: *Psalm 72 Selected Verses*

- P** Give the king your justice, O God, and your righteousness to the royal son!
- C** **May he judge your people with righteousness, and your poor with justice!**
- P** Let the mountains bear prosperity for the people, and the hills, in righteousness!
- C** **May he defend the cause of the poor of the people, give deliverance to the children of the needy, and crush the oppressor!**
- P** May they fear you while the sun endures, and as long as the moon, throughout all generations!
- C** **In his days may the righteous flourish, and peace abound, till the moon be no more!**
- P** Blessed be the LORD, the God of Israel, who alone does wondrous things.
- C** **Blessed be his glorious name forever; may the whole earth be filled with his glory! Amen and Amen!**



The Epistle Reading: *Romans 15:4-13*

For whatever was written in former days was written for our instruction, that through endurance and through the encouragement of the Scriptures we might have hope. ⁵ May the God of endurance and encouragement grant you to live in such harmony with one another, in accord with Christ Jesus, ⁶ that together you may with one voice glorify the God and Father of our Lord Jesus Christ. ⁷ Therefore welcome one another as Christ has welcomed you, for the glory of God. ⁸ For I tell you that Christ became a servant to the circumcised to show God's truthfulness, in order to confirm the promises given to the patriarchs, ⁹ and in order that the Gentiles might glorify God for his mercy. As it is written, "Therefore I will praise you among the Gentiles, and sing to your name." ¹⁰ And again it is said, "Rejoice, O Gentiles, with his people." ¹¹ And again, "Praise the Lord, all you Gentiles, and let all the peoples extol him." ¹² And again Isaiah says, "The root of Jesse will come, even he who arises to rule the Gentiles; in him will the Gentiles hope." ¹³ May the God of hope fill you with all joy and peace in believing, so that by the power of the Holy Spirit you may abound in hope.

P Blessed are they who hear the Word of God and keep it.

Al-le-lu-ia! Al-le-lu-ia! Al-le-lu-ia! These words are
writ-ten that we may believe that Je-sus is the Christ, the
Son of God. Al-le-lu-ia! Al-le-lu-ia! Al-le-lu-ia!

The Apostle's Creed

We boldly confess what we believe.

C I believe in God, the Father Almighty, Maker of heaven and earth.

I believe in Jesus Christ, His only Son, our Lord, who was conceived by the Holy Spirit, born of the virgin Mary, suffered under Pontius Pilate, was crucified, died and was buried. He descended into hell. The third day He rose again from the dead. He ascended into heaven; And is seated at the right hand of God the Father Almighty. From there He will come to judge the living and the dead

I believe in the Holy Spirit, the holy Christian Church, the communion of saints, the forgiveness of sins, the resurrection of the body, and the life everlasting. Amen.

Hymn 349 *Hark the Glad Sound*

**1 Hark the glad sound! The Savior comes, The Savior promised long;
Let ev'ry heart prepare a throne And ev'ry voice a song.**

**2 He comes the pris'ners to release, In Satan's bondage held.
The gates of brass before Him burst, The iron fetters yield.**

**3 He comes the broken heart to bind, The bleeding soul to cure,
And with the treasures of His grace To enrich the humble poor.**

**4 Our glad hosannas, Prince of Peace, Thy welcome shall proclaim,
And heav'n's eternal arches ring With Thy beloved name.**

The Sermon: Matthew 3:1-12

In those days John the Baptist came preaching in the wilderness of Judea, ² "Repent, for the kingdom of heaven is at hand." ³ For this is he who was spoken of by the prophet Isaiah when he said, "The voice of one crying in the wilderness: 'Prepare the way of the Lord; make his paths straight.'" ⁴ Now John wore a garment of camel's hair and a leather belt around his waist, and his food was locusts and wild honey. ⁵ Then Jerusalem and all Judea and all the region about the Jordan were going out to him, ⁶ and they were baptized by him in the river Jordan, confessing their sins. ⁷ But when he saw many of the Pharisees and Sadducees coming to his baptism, he said to them, "You brood of vipers! Who warned you to flee from the wrath to come? ⁸ Bear fruit in keeping with repentance. ⁹ And do not presume to say to yourselves, 'We have Abraham as our father,' for I tell you, God is able from these stones to raise up children for Abraham. ¹⁰ Even now the axe is laid to the root of the trees. Every tree therefore that does not bear good fruit is cut down and thrown into the fire. ¹¹ "I baptize you with water for repentance, but he who is coming after me is mightier than I, whose sandals I am not worthy to carry. He will baptize you with the Holy Spirit and fire. ¹² His winnowing fork is in his hand, and he will clear his threshing floor and gather his wheat into the barn, but the chaff he will burn with unquenchable fire."

Theme: REPENT, THE REIGN OF CHRIST IS NEAR!

Summary: *John the Baptist was the prophesied Forerunner who prepared the way for the first coming of the Messiah Jesus Christ. John did this by preaching repentance—a turning away from sin and turning toward God for forgiveness. It was a hard message for some, but necessary, nonetheless. Christians today are awaiting the second coming of the Messiah Jesus Christ. Our preparation is the same; we are called to repent of our sins and trust in the Lord Jesus for forgiveness, life, and eternal salvation. The reign of Christ means judgment for the rebellious, but sweet relief and healing for the repentant.*

Sermon Worksheet:

Who was John the Baptist's mother? How much older was John than Jesus?

What did Malachi and Isaiah prophesy John would do for Jesus?

Why is the English translation "kingdom" confusing? What is a better word?

How were religious people of John's day similar to religious people today?

What does it mean that repentance is a "Spirit-worked action"?

What is the cause of all suffering, sadness, and death in the world?

What will happen in eternity to those who reject Jesus and refuse to repent?

What big difference is there between John's message then vs. now?

What will happen in eternity to those who repent and trust in Jesus for forgiveness?

The Offertory

Having heard God's Word, we pray for spiritual healing through the gift of the Holy Spirit.

Cre-ate in me a clean heart, O God, and re -
new a right spir-it with - in me. Cast me not a -
way from Your pres - ence. Take not Your Ho - ly
Spir-it from me. Re store to me the joy of Your sal -
va - tion. Up - hold with Your Spir - it free.

Hymn 346 *When All the World Was Cursed*

1 *When all the world was cursed By Moses' condemnation,
Saint John the Baptist came With words of consolation.
With true forerunner's zeal The greater One he named,
And Him as yet unknown, As Savior he proclaimed.*

2 *Before he yet was born, He leaped in joyful meeting,
Confessing Him as Lord Whose mother he was greeting.
By Jordan's rolling stream, A new Elijah bold,
He testified of Him Of whom the prophets told:*

3 *Behold the Lamb of God That bears the world's transgression,
Whose sacrifice removes The devil's dread oppression.
Behold the Lamb of God, Who takes away our sin,
Who for our peace and joy Will full atonement win.*

4 *O grant, dear Lord of love, That we receive, rejoicing,
The word proclaimed by John, Our true repentance voicing,
That gladly we may walk Upon our Savior's way
Until we live with Him In His eternal day.*

The Offering of Thankful Hearts

In tangible evidence of our gratitude, we offer the Lord the gift of our money, remembering that He has first given to us that we might have to give to Him. If you wish to give your church offering electronically, you can do so by using the CashApp on your mobile device. The church's Scashtag is "Scclmtzion". While the usher brings the offering plate forward we sing the following hymn verse:

**Lord, You love the cheerful giver Who with open heart and hand
Blesses freely, as a river That refreshes all the land.
Grant us, then, the grace of giving With a spirit large and true
That our life and all our living We may consecrate to You.**

Prayer of the Church – The Lord's Prayer

C Our Father who art in heaven, hallowed be Thy name, Thy kingdom come, Thy will be done on earth as it is in heaven. Give us this day our daily bread; and forgive us our trespasses as we forgive those who trespass against us; and lead us not into temptation, but deliver us from evil. For Thine is the kingdom and the power and the glory forever and ever. Amen.

The Service of the Sacrament

Now we approach the second high point of the liturgy, the Sacrament, in which the Lord comes to bless us with His very body and blood. We move toward the Sacrament with prayers of thanksgiving and songs of adoration.

P The Lord be with you.

C And also with you.

P Lift up your hearts.

C We lift them up to the Lord.

P It is right and beneficial that we should at all times and in all places give thanks to You, O Lord, holy Father, almighty and everlasting God, through Jesus Christ our Lord, whose way John the Baptist prepared, proclaiming Him the Messiah, the very Lamb, and calling sinners to repentance that they might escape from the wrath to be revealed when He comes again in glory; Therefore with angels and archangels and all the company of heaven, we magnify Your glorious Name, evermore praising You and saying...

Holy, Holy, Holy

The Sanctus – Latin for “Holy.” We join our voices to the angels who sing, “Holy, Holy, Holy” around His throne.”



Ho-ly, ho-ly, ho-ly Lord, God of Sa-ba-oth, a-dored; Heav'n and
earth with full ac-claim shout the glo-ry of Your name. Sing ho -
san-na in the high-est, sing ho - san-na to the Lord; Tru-ly
blest is He who comes in the name of the Lord!

Words of Institution

The words spoken by Jesus the night He instituted the Lord's Supper by which our Lord assured to His Church the real presence of His sacramental body and blood for all time.

P Our Lord Jesus Christ, the same night in which He was betrayed, took bread. And when He had given thanks, He broke it and gave it to His disciples, saying, “Take, eat. This is My body, which is given for you. Do this in remembrance of me.”

In the same way He took the cup, after supper, gave thanks, and gave it to them saying, “Drink of it, all of you. This cup is the new covenant in My blood, which is shed for the forgiveness of sins. Do this, whenever you drink it, in remembrance of Me.”

The peace of the Lord be with you always!

Lamb of God

The Agnus Dei – Latin for “Lamb of God.” As we approach the Table of Forgiveness, we want to be thinking about the Lamb of God who was sacrificed for us on Calvary’s cross.

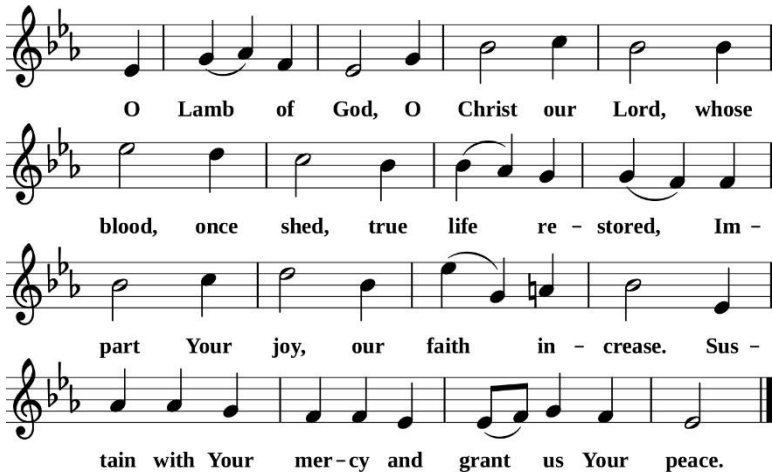

O Lamb of God, O Christ our Lord, whose
blood, once shed, true life re - stored, Im -
part Your joy, our faith in - crease. Sus -
tain with Your mer - cy and grant us Your peace.

Distribution of the Sacrament

Communion Today is for Members Only Please

We don't judge anyone's faith, but we do stand up for our own. The Bible teaches what we call "Close Communion," that is, God wants you to commune only with those people with whom you are agreed in ALL the Bible's teachings. This belief is based upon the Bible passages listed below. Therefore, if you are a guest with us today, and BEFORE you come up to commune with us, you'll want to find out if our church teaches what the Bible does! The pastor would be happy to discuss this with you at your convenience!

1 Corinthians 1:10 "Now I plead with you, brethren, by the name of our Lord Jesus Christ, that you all speak the same thing, and that there be no divisions among you, but that you be perfectly joined together in the same mind and in the same judgment."

1 Corinthians 11:26-30 "For as often as you eat this bread and drink this cup, you proclaim the Lord's death till He comes. Therefore whoever eats this bread or drinks this cup of the Lord in an unworthy manner will be guilty of the body and blood of the Lord.

But let a man examine himself, and so let him eat of that bread and drink of that cup. For he who eats and drinks in an unworthy manner eats and drinks judgment to himself, not discerning the Lord's body."



O Lord, Now Let Your Servant

The Nunc Dimittis – Latin for “Now Dismiss.” Simeon’s words after seeing the Christ Child. (Luke 2:29-32)

O Lord, now let Your ser - vant De - part in heav'n-ly
All glo - ry to the Fa - ther, All glo - ry to the
peace, For I have seen the glo - ry Of Your re - deem - ing
Son, All glo - ry to the Spir - it, For - ev - er Three - in -
grace: A light to lead the Gen - tiles Un - to Your ho - ly
One; For as in the be - gin - ning, Is now, shall ev - er
hill, The glo - ry of Your peo - ple, Your
be, God's tri - une name re - sound - ing Through
cho - sen Is - ra - el.
all e - ter - ni - ty.

P Go in peace. Serve the Lord with gladness.

Thanksgiving

We give thanks and praise the LORD for the forgiveness of sins received in the Sacrament.

My heart has now be come Your dwelling, O blessed ho - ly Trin - i -
ty. With an - gels I, Your prais - es tell - ing, Shall live in
joy e - ter - nal - ly. Lord, may Your bod - y and Your
blood Be for my soul the high - est good!

The Benediction

The blessing given by God for His people (Numbers 6:24-26)

P The Lord bless you and keep you.

The Lord make His face shine upon you and be gracious unto you.

The Lord lift up His countenance upon you and give you peace.

G Amen!

Closing Hymn 515:4 *Rejoice, Rejoice, Believers*

*4 Our hope and expectation,
O Jesus, now appear;
Arise, O Sun so longed for,
O'er this benighted sphere.
With hearts and hands uplifted,
We plead, O Lord, to see
The day of earth's redemption
That sets Your people free!*

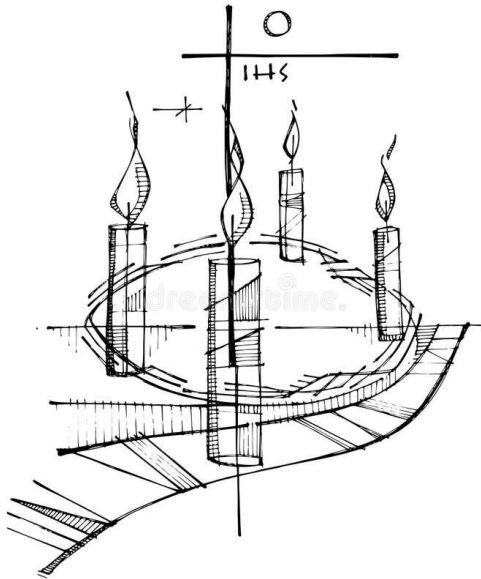

LIVESTREAM on  **YouTube** @MtZionLutheranChurch

SERMON PODCAST on  **Spotify** @TheWordFromMtZion

Hymns and liturgical settings under copyright are used by permission through Concordia Publishing House License #000014224 or OneLicense.net #A-732884. All Rights reserved. Used by permission. Unless otherwise indicated, Scripture quotations are from the ESV® Bible (The Holy Bible, English Standard Version®), copyright © 2001 by Crossway, a publishing ministry of Good News Publishers. Used by permission. All rights reserved.

ANNOUNCEMENTS

If the LORD wills, we will do this or that. James 4:15

WELCOME EVERYONE! We pray that God's Word and our worship today will help you grow in the grace and knowledge of our Savior Jesus.

- † Restrooms are located to the left after you exit down the main aisle.
- † A Parents Room is located in the back of the sanctuary.
- † If you are visiting with us today, please sign the Guest Book in the back.
- † If you are looking for a church home, ask Pastor Tom about a free one-on-one Bible study for new people. Where & when? Your convenience.

SECOND MIDWEEK ADVENT SERVICE AND SOUP SUPPER: This Wed. December 10 is our second midweek Advent service at 7pm. There will again be a soup supper (two soups, bread, and dessert) at 6pm. All are welcome! Our midweek Advent theme this year is *God's Christmas Trees*. Join us for this extra opportunity for fellowship and God's Word!

Date	Preacher	Sermon Text and Theme
Dec. 6	Pastor Tom Naumann	Revelation 22:1-2 <i>The Tree of Life</i>
Dec. 10	Pastor Mike Wilke	Psalms 1:1-3 <i>The Tree of the Believer</i>
Dec. 17	Pastor Stefan Sonnenfeld	Galatians 3:10-13 <i>The Tree of the Cross</i>

CHRISTMAS SERVICES: Please share the Christmas Service invitation found inside your bulletin with a friend or neighbor. Let's pack God's house this Christmas!

Children's Christmas Eve Service: Wednesday, December 24 at 4:00pm. All are invited to this special service where, with the help of the congregation's children, we will be reading through the Biblical Christmas account, singing favorite Christmas carols, and celebrating the birth of our Savior Jesus!

Christmas Day Service: Thursday, December 25 at 10:00am. All are invited to our traditional Christmas Day service where we will praise God for our Savior's birth in Word and song.

A POST-CHRISTMAS PARTY is being planned by LIFT for Friday, January 9 at 5:30pm. Food & games! Everyone is welcome, so please mark your calendar.

UPCOMING CALENDAR

Tue. 12/9	7-9pm	Church Meetings (Elders/Council/Trustees/Ed)
Wed. 12/10	6pm	Soup Supper (see the bulletin board sign-up sheet)
	7pm	2 nd Midweek Advent Service (Pastor Wilke)
Thu. 12/11	8pm	Compensation Committee Meeting
Sun. 12/14	9am	Bible Class/Sunday School
	10am	Divine Worship Service (w/ Communion)
Wed. 12/24	4pm	Christmas Eve Worship Service (Children's Program)
Thu. 12/25	10am	Christmas Day Worship Service
Sun. 1/18	11am	Q1 Voters Meeting

SERVING US THIS WEEK:

Usher: Randy Wittorp **A/V Coordinator:** Randy Wittorp **Church Cleaners:** Voelzke

OUR RESPONSE TO THE GOSPEL

Last Sunday Attendance = 34 Bible Class/Sunday School = 22

General Fund Offerings Budgeted YTD: \$114,461.76	Weekly General Fund Offerings Budgeted: \$2,384.62
General Fund Offerings Received YTD: \$110,848.00	Last Week's General Fund Offerings Received: \$1,064.00
Building Fund Offerings Received YTD: \$22,740.00	School Fund (Maisie Wittorp Christian Education Fund): \$67,250.68
Building Fund Balance: \$8,274.45	Missions Offerings YTD: \$5,813.00

IN OUR PRAYERS <> ENCOURAGEMENT LIST

Be alert and always keep on praying for all the Lord's people. Ephesians 6:18

Jackie McGruder remains homebound as she continues to suffer from lupus. **Dave and Peggy Green** remain homebound as Dave continues to suffer from a very debilitating form of Parkinson's disease. **Our congregation** continues to pray for a buyer for our old church property at 26689 Northeastern Hwy.

CHURCH OF THE LUTHERAN CONFESSION SYNODWIDE ANNOUNCEMENTS

Behold, how good and pleasant it is when brothers dwell in unity! Psalm 133:1

CALL NEWS Pastor Johnathan Schnose of Bethel Ev. Lutheran Church, Morris, MN, has **returned** the call to Living Hope Lutheran Church, Appleton, WI. <> Pastor Emeritus Michael Eichstadt has **accepted** the vacancy call to Holy Cross Ev. Lutheran Church, Phoenix, AZ. <> Pastor Dave Naumann of St. John's Lutheran Church, Clarkston, WA, and Peace Lutheran Church, Orofino, ID, has **received** the call to Trinity Ev. Lutheran Church, Spokane, WA. <> Pastor Terrel Kesterson of Ascension Lutheran Church, Batavia, IL, has **received** the part-time call to Our Redeemer's Lutheran Church, Red Wing, MN. <> Pastor Ben Libby of Redeemer Ev. Lutheran Church, Cheyenne, WY, has **received** the call to Holy Cross Ev. Lutheran Church, Phoenix, AZ. <> Pastor Ben Libby of Redeemer Ev. Lutheran Church, Cheyenne, WY, has **received** the call to Messiah Lutheran Church, Eau Claire, WI.

INSTALLATION Pastor Michael Gurath will be installed at Peace Thru Christ Lutheran Church, Middleton, WI, on December 21, 2025.

2026 CLC MISSION HELPER TRIP: The CLC Mission Helper Program is making preparations for another Mission Trip to Africa for the summer of 2026. The main focus of this trip will be presenting the Gospel, through a series of child evangelism lessons, to member and non-member children in village congregations. Possible areas of evangelism include the CLC-Tanzania, CLC-Kenya, CLC-Zambia, and CLC-Uganda. CLC members are welcome and encouraged to apply. For more information and to apply, visit www.mht.lutheranmissions.org.

ILC CHRISTMAS CONCERT: The choirs of Immanuel Lutheran High School, College, and Seminary will be presenting Light Born From Light (O Nata Lux de Lumine) on Friday, December 19, 2025 at Messiah Lutheran Church, 2015 N Hastings Way, Eau Claire, WI 54703. The evening will begin at 7:00 p.m., with the strings, band, and flute choir presenting several songs prior to the choral service. It is open to the public and admission is free. The service will also be streaming live at youtube.com/ilc.videos